

Traglasten für reduzierte Abstützung auf Anfrage

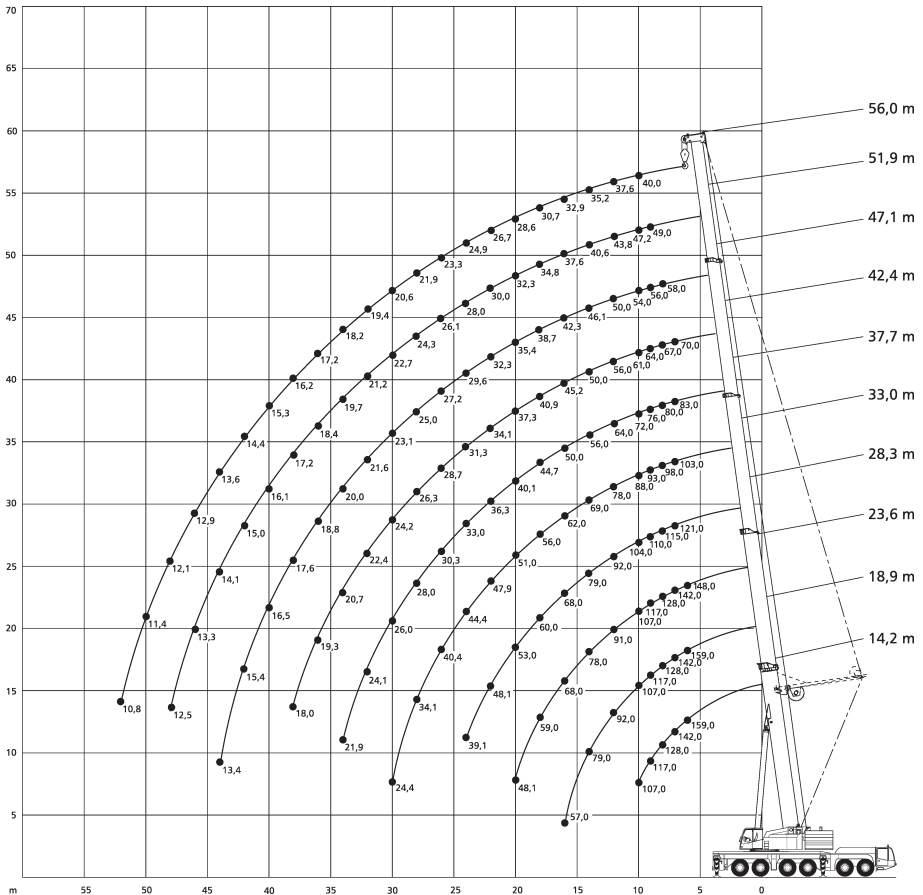



Die Arbeitsbereiche





14,2-56m



8,5x8,52m



142t



360°



75%

	14,2	18,9	23,6	28,3	33	37,7	42,4	47,1	51,9	56	
6	159*	159*	148*								6
7	142*	142*	142*	121	103	83	70				7
8	128	128	128	115	98	80	67	58			8
9	117	117	117	110	93	76	64	56	49		9
10	107	107	107	104	88	72	61	54	47,2	40	10
12		92	91	92	78	64	56	50	43,8	37,6	12
14		79	78	79	69	56	50	46,1	40,6	35,2	14
16		57	68	68	62	50	45,2	42,3	37,6	32,9	16
18			59	60	56	44,7	40,9	38,7	34,8	30,7	18
20			48,1	53	51	40,1	37,3	35,4	32,3	28,6	20
22				48,1	47,9	36,3	34,1	32,3	30	26,7	22
24				39,1	44,4	33	31,3	29,6	28	24,9	24
26					40,4	30,3	28,7	27,2	26,1	23,3	26
28					34,1	28	26,3	25	24,3	21,9	28
30					24,4	26	24,2	23,1	22,7	20,6	30
32						24,1	22,4	21,6	21,2	19,4	32
34						21,9	20,7	20	19,7	18,2	34
36							19,3	18,8	18,4	17,2	36
38							18	17,6	17,2	16,2	38
40								16,5	16,1	15,3	40
42								15,4	15	14,4	42
44								13,4	14,1	13,6	44
46									13,3	12,9	46
48									12,5	12,1	48
50										11,4	50
52										10,8	52

* mit Sonderausrüstung





14,2-56m



8,5x8,52m



122t



360°



75%

	14,2*	14,2	18,9	23,6	28,3	33	37,7	42,4	47,1	51,9	56	
3	350**	237**	175**	160**								3
3,5	237**	220**	174**	159**								3,5
4	222**	204**	172**	158**	130							4
4,5	210**	190**	170**	156**	130							4,5
5	198**	177**	167**	154**	129	109						5
6	175**	157**	156**	148**	125	106	86					6
7	153**	140**	139**	140**	121	103	83	70				7
8	134**	126	126	126	115	98	80	67	58			8
9	119	115	115	115	110	93	76	64	56	49		9
10	107	105	105	105	104	88	72	61	54	47,2	40	10
12			88	88	88	78	64	56	50	43,8	37,6	12
14			75	74	75	69	56	50	46,1	40,6	35,2	14
16			57	64	65	62	50	45,2	42,3	37,6	32,9	16
18				56	57	56	44,7	40,9	38,7	34,8	30,7	18
20				48,1	50	51	40,1	37,3	35,4	32,3	28,6	20
22					43,6	44,7	36,3	34,1	32,3	30	26,7	22
24					38,5	39,5	33	31,3	29,6	28	24,9	24
26						35,2	30,3	28,7	27,2	26,1	23,3	26
28						31,7	28	26,3	25	24,3	21,9	28
30						24,4	26	24,2	23,1	22,7	20,6	30
32							24,1	22,4	21,6	21,2	19,4	32
34							21,9	20,7	20	19,7	18,2	34
36								19,3	18,8	18,4	17,2	36
38								18	17,6	17,2	16,2	38
40									16,5	16,1	15,3	40
42									15,4	15	14,4	42
44									13,4	14,1	13,6	44
46										13,3	12,9	46
48										12,5	12,1	48
50											11,4	50
52											10,8	52

*nach hinten

** mit Sonderausrüstung



14,2-56m



8,5x8,52m



82t



360°



75%

	14,2	18,9	23,6	28,3	33	37,7	42,4	47,1	51,9	56	
3	231*	175*	160*								3
3,5	213*	174*	159*								3,5
4	197*	172*	158*	130							4
4,5	184*	170*	156*	130							4,5
5	171*	167*	154*	129	109						5
6	151*	151*	148*	125	106	86					6
7	135*	134*	135*	121	103	83	70				7
8	121	121	120	115	98	80	67	58			8
9	107	107	106	107	93	76	64	56	49		9
10	96	96	95	96	88	72	61	54	47,2	40	10
12		78	78	78	78	64	56	50	43,8	37,6	12
14		61	62	61	62	56	50	46,1	40,6	35,2	14
16		49,8	50	51	50	50	45,2	42,3	37,6	32,9	16
18			42,4	43,6	42,5	41,8	40,9	38,7	34,8	30,7	18
20			36,2	37,3	36,3	35,6	35,6	35,4	32,3	28,6	20
22				32,4	31,4	31,2	30,7	31,1	30	26,7	22
24				28,6	28,6	28	26,8	27,2	27,9	24,9	24
26					26,1	24,7	23,6	24	24,6	23,3	26
28					23,4	22,1	21	21,3	21,9	21,9	28
30					21,2	19,8	19,8	19,6	19,6	19,7	30
32						18,3	18,5	18,3	17,7	17,8	32
34						16,8	16,8	16,6	16	16,1	34
36							15,4	15,1	14,5	14,6	36
38							14,2	13,8	13,2	13,3	38
40								12,7	12	12	40
42								11,6	10,9	10,9	42
44								10,6	9,9	9,9	44
46									9	9	46
48									8,2	8,2	48
50										7,5	50
52										6,8	52

*mit Sonderausrüstung





14,2-56m



8,5x8,52m



52t



360°



DIN

75%

	14,2	18,9	23,6	28,3	33	37,7	42,4	47,1	51,9	56	
3	225*	175*	160*								3
3,5	207*	174*	159*								3,5
4	192*	172*	158*	130							4
4,5	179*	170*	156*	130							4,5
5	167*	166*	154*	129	109						5
6	147*	146*	146*	125	106	86					6
7	127	127	126	117	103	83	70				7
8	109	109	104	98	93	80	67	58			8
9	93	94	92	83	80	74	64	56	49		9
10	77	77	78	73	70	65	61	54	47,2	40	10
12		59	57	59	56	52	50	48,4	43,8	37,6	12
14		46	46,5	46,1	44,9	44,7	40,9	39,8	39,2	35,2	14
16		37,3	37,7	37,3	38,3	36,7	33,9	34,4	32,9	32	16
18			31,3	31,8	31,8	30,9	30,8	30	28	27,4	18
20			27,1	27,2	26,7	25,9	26,7	25,8	24,2	23,6	20
22				23,3	22,8	23	22,7	21,9	21	20,6	22
24				20,2	19,7	19,9	19,7	18,9	18,2	18	24
26					17,9	17,4	17,1	16,4	15,7	15,8	26
28					15,8	15,4	15,1	14,3	13,7	13,8	28
30					14,1	13,6	13,3	12,6	11,8	12	30
32						12,2	11,9	11	10,3	10,4	32
34						10,9	10,5	9,7	8,9	9	34
36							9,4	8,5	7,8	7,9	36
38							8,4	7,5	6,8	6,8	38
40								6,6	5,9	5,9	40
42								5,8	5,1	5,1	42
44								5,2	4,4	4,4	44
46									3,8	3,8	46
48									3,2	3,2	48
50										2,7	50
52										2,3	52

*mit Sonderausrüstung

 33-56m
 SSL0°

8,5x8,52m





142t



360°



75%

	33	37,7	42,4	47,1	51,9	56	
5	117	95					5
6	113	92	80				6
7	109	90	78	66			7
8	105	87	76	64	58*	53*	8
9	102	84	74	62	56*	51*	9
10	98	81	72	60	54*	49,2*	10
12	87	76	68	57	50*	45,4*	12
14	76	71	64	54	47,5	42,3*	14
16	65	65	60	51	45,5	39,6*	16
18	57	58	56	48,1	43,6	37,2*	18
20	50	51	52	45,5	41,7	35,2	20
22	45,1	45,9	46,5	43,2	40	33,7	22
24	40,4	41,2	41,8	41	38,2	32,3	24
26	34,7	37,3	37,8	38,6	36,4	30,9	26
28	28,2	33,7	34,4	35,3	34,2	29,4	28
30	18,8	29,3	31,4	32,3	32,2	28,1	30
34		17,9	25	26,8	27,5	25,7	34
38			16,4	22,2	23,2	23,3	38
42				15,3	19,2	19,9	42
46					13,9	16,5	46
50						11,8	50

*SSL 30°





33-56m
SSL0°



8,5x8,52m



122t



360°



75%

	33	37,7	42,4	47,1	51,9	56	
5	117	95					5
6	113	92	80				6
7	109	90	78	66			7
8	105	87	76	64	58*	53*	8
9	102	84	74	62	56*	51*	9
10	98	81	72	60	54*	49,2*	10
12	86	76	68	57	50*	45,4*	12
14	72	71	64	54	47,5	42,3*	14
16	62	63	60	51	45,5	39,6*	16
18	54	55	55	48,1	43,6	37,2*	18
20	47,7	48,5	49,1	45,5	41,7	35,2	20
22	41,2	42,3	43	43,2	40	33,7	22
24	36	36,9	37,7	38,7	38,2	32,3	24
26	31,7	32,6	33,3	34,3	35,1	30,9	26
28	28,1	29	29,7	30,6	31,4	29,4	28
30	18,8	25,9	26,6	27,5	28,3	28,1	30
34		17,9	21,7	22,5	23,2	23,4	34
38			16,4	18,8	19,4	19,6	38
42				15,3	16,4	16,6	42
46					13,9	14	46
50						11,8	50

*SSL 30°

33-56m
SSL0°

8,5x8,52m



82t



360°



75%

	33	37,7	42,4	47,1	51,9	56	
5	117	95					5
6	113	92	80				6
7	109	90	78	66			7
8	105	87	76	64	58*	53*	8
9	102	84	74	62	56*	51*	9
10	93	81	72	60	54*	49,2*	10
12	74	72	68	57	50*	45,4*	12
14	59	59	58	54	47,5	42,3*	14
16	47,7	48,8	49	48,7	45,5	39,6*	16
18	39,2	40,3	41,2	42	41,7	37,2*	18
20	32,8	33,9	34,7	35,8	36,5	35,2	20
22	27,9	28,9	29,7	30,7	31,6	31,7	22
24	23,9	24,9	25,7	26,7	27,5	27,7	24
26	20,7	21,6	22,4	23,4	24,1	24,3	26
28	17,9	18,9	19,6	20,6	21,3	21,5	28
30	15,6	16,5	17,2	18,2	19	19,1	30
34		12,6	13,3	14,3	15,1	15,3	34
38			10,4	11,3	12,1	12,2	38
42				9	9,7	9,8	42
46					7,8	7,9	46
50						6,3	50

*SSL 30°





33-56m
SSL0°



8,5x8,52m



52t



360°



DIN

75%

	33	37,7	42,4	47,1	51,9	56	
5	117	95					5
6	113	92	80				6
7	106	90	78	66			7
8	89	85	76	64	54	45,5	8
9	76	73	70	62	53	44,5	9
10	66	64	61	60	52	43,5	10
12	51	50	49,1	48,4	47,5	41,6	12
14	41,3	40,8	40,1	39,8	39,4	38,3	14
16	32,6	33,4	33	33,1	32,9	32,1	16
18	26,1	27,4	27,4	27,8	27,8	27,2	18
20	21,1	22,2	23,1	23,5	23,7	23,3	20
22	17	18,2	19,1	20,1	20,4	20,1	22
24	13,7	14,9	15,8	17	17,7	17,4	24
26	11,1	12,2	13,1	14,3	15,2	15,2	26
28	9	10	10,9	12	12,9	13,1	28
30	7,3	8,2	9	10,1	11	11,2	30
32		6,7	7,4	8,5	9,4	9,6	32
34		5,4	6,1	7,1	7,9	8,1	34
36			4,9	5,9	6,7	6,9	36
38			3,9	4,9	5,7	5,8	38
40				4	4,7	4,9	40
42				3,2	3,9	4	42
44					3,2	3,3	44
46					2,5	2,6	46
48						2	48



Die Arbeitsbereiche

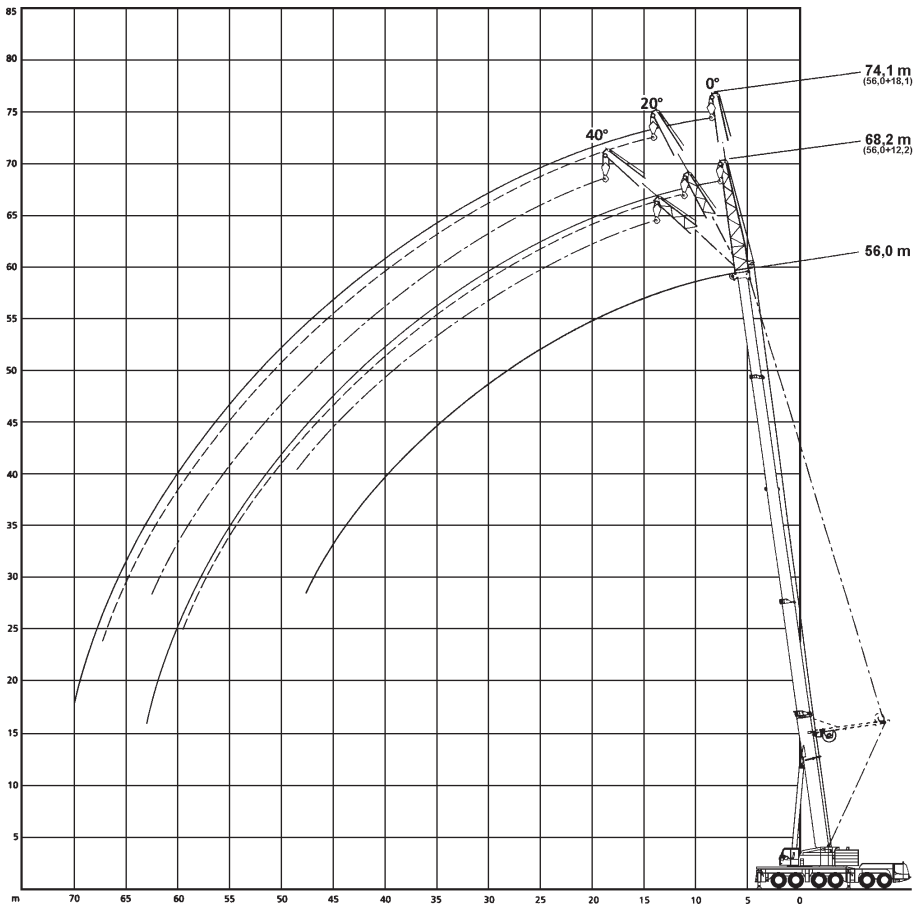



51,9m



12,2/18,1m



8,5x8,52m



122t



360°



DIN

75%

	12,2			18,1			
	0°	20°	40°	0°	20°	40°	
12	27,1			17			12
14	25,7			16,7			14
16	24,3	17,5		16,4			16
18	23	16,7	12,9	16	14,4		18
20	21,7	16,1	12,6	15,7	13,9		20
22	20,4	15,5	12,3	15,3	13,4	11,5	22
24	19,1	14,9	12,1	14,9	13	11,3	24
26	17,8	14,4	11,9	14,5	12,6	11,1	26
28	16,6	14	11,7	14	12,2	10,9	28
30	15,6	13,5	11,5	13,6	11,8	10,8	30
34	13,9	12,8	11,2	12,6	11,2	10,4	34
38	12,7	12,1	11	11,4	10,7	10,1	38
42	11,7	11,3	10,8	10,4	9,9	9,7	42
46	10,8	10,6	10,6	9,5	9,2	9,1	46
50	9,8	9,8		8,8	8,6	8,6	50
54	8,8	9		8,2	8		54
58	7,9			7,5	7,5		58
62				6,9	7		62



	12,2			18,1			
	0°	20°	40°	0°	20°	40°	
14	22,6			14,7			14
16	21,1	17,3		14,5			16
18	19,7	16,6	12,9	14,2			18
20	18,5	16	12,6	13,9	13,4		20
22	17,3	15,4	12,4	13,5	12,7		22
24	16,4	14,7	12,1	13,1	12,1	11,1	24
26	15,5	14,1	11,9	12,6	11,6	10,6	26
28	14,7	13,5	11,6	12,2	11	10,2	28
30	13,9	12,9	11,3	11,7	10,6	9,8	30
34	12,6	11,8	10,8	10,7	9,7	9,1	34
38	11,5	10,9	10,3	9,8	8,9	8,5	38
42	10,5	10,1	9,8	9	8,3	7,9	42
46	9,6	9,4	9,3	8,3	7,7	7,5	46
50	8,9	8,8		7,7	7,2	7,1	50
54	8,2	8,2		7,2	6,8	6,8	54
58	7,5	7,5		6,7	6,5		58
62	6,8			6,2	6,1		62
66				5,8	5,8		66
70				3,1			70





51,9m
SSL30°



12,2/18,1m



8,5x8,52m



142t



360°



75%

	12,2			18,1			
	0°	20°	40°	0°	20°	40°	
10	34,1			21,4			10
12	33,7			21,1			12
14	32,5	20		20,6			14
16	30,7	19	13,7	20	16,5		16
18	28,8	18,1	13,3	19,4	15,9		18
20	26,9	17,3	13	18,6	15,2	12,2	20
22	25,1	16,6	12,7	17,9	14,6	11,9	22
24	23,4	16	12,4	17,1	14,1	11,7	24
26	21,8	15,4	12,2	16,4	13,6	11,4	26
28	20,3	14,8	12	15,7	13,2	11,3	28
30	19,1	14,4	11,8	15	12,7	11,1	30
34	17,1	13,5	11,4	13,9	12	10,8	34
38	15,5	12,8	11,2	13	11,4	10,5	38
42	14,1	12,2	11	12,1	10,8	10,2	42
46	13	11,7	11	11,4	10,4	10	46
50	12	11,3		10,8	10	9,8	50
54	11,2	10,8		10,3	9,7		54
58	9,6			9,8	9,5		58
62				8,7	9		62

56m
SSL30°

12,2/18,1m



8,5x8,52m



142t



360°



75%

	12,2			18,1			
	0°	20°	40°	0°	20°	40°	
12	33,6			20,5			12
14	31,7	20,1		20,1			14
16	29,8	19,2	13,7	19,6			16
18	28,1	18,3	13,4	19	15,7		18
20	26,4	17,5	13,1	18,3	15,1		20
22	24,8	16,8	12,8	17,6	14,6	11,9	22
24	23,4	16,2	12,5	16,9	14,1	11,7	24
26	22	15,6	12,3	16,3	13,6	11,5	26
28	20,8	15,1	12,1	15,6	13,2	11,3	28
30	19,7	14,7	11,9	15	12,8	11,1	30
34	17,7	13,8	11,6	14	12	10,8	34
38	16,1	13,1	11,3	13,1	11,4	10,5	38
42	14,7	12,5	11,1	12,3	10,9	10,2	42
46	13,5	12	11	11,5	10,4	10	46
50	12,5	11,6	11	10,8	10,1	9,8	50
54	11,3	11,2		10,1	9,7	9,7	54
58	9,5	9,7		9,4	9,4		58
62	8			8,5	8,9		62
66				7,2	7,5		66





Die Arbeitsbereiche

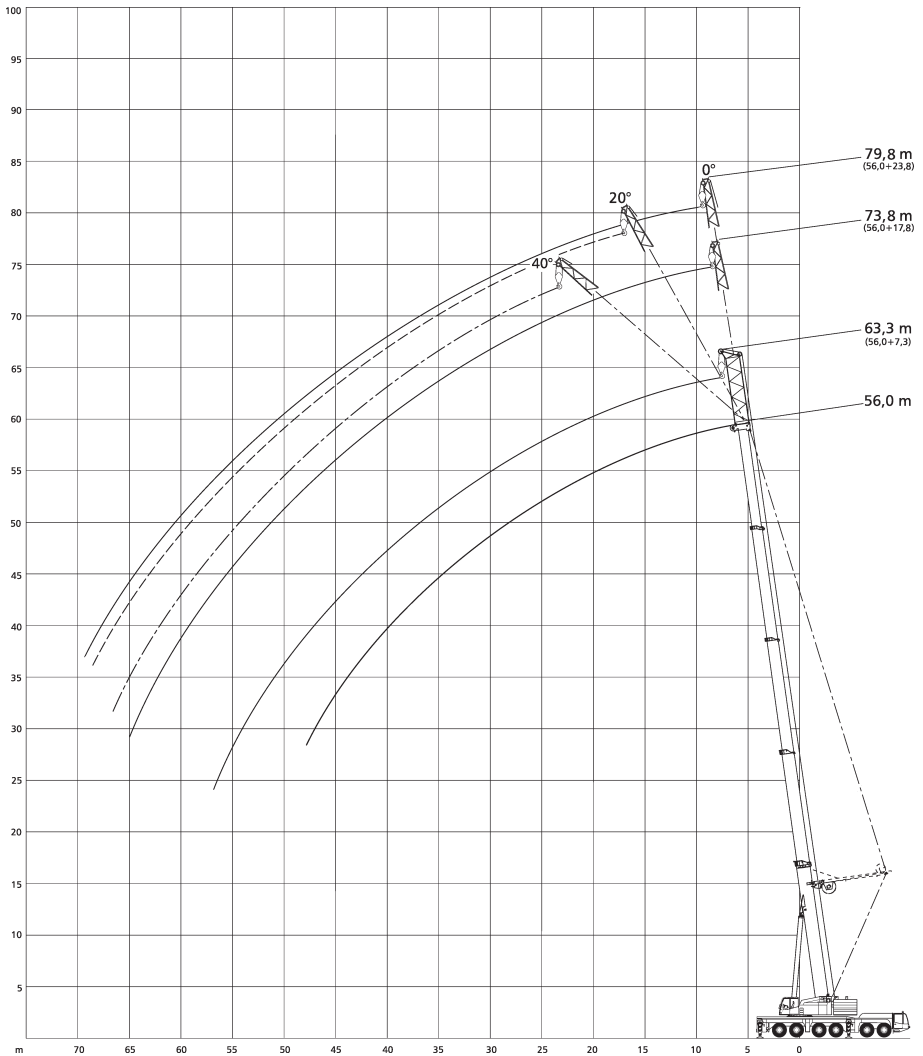





51,9m	7,3-23,8m LF	8,5x8,52m	122t	360°	75%

	7,3 0°	17,8 0°	0°	23,8 20°	40°	
12	31,3					12
14	29	21,9	18,1			14
16	26,9	20,8	17			16
18	25,1	19,8	16,1			18
20	23,4	18,8	15,2			20
22	22	17,8	14,5	10,8		22
24	20,7	16,9	13,8	10,4		24
26	19,6	16,1	13,1	10		26
28	18,6	15,3	12,5	9,7	8	28
30	17,7	14,5	12	9,4	7,9	30
34	16,1	13,2	11	8,8	7,6	34
38	14,7	12	10,2	8,3	7,3	38
42	13,3	11	9,4	7,9	7,1	42
46	12	10,1	8,7	7,6	6,9	46
50	10,7	9,4	8,1	7,3	6,8	50
54	9,4	8,7	7,5	7,1	6,8	54
58		8,1	7	6,8	6,8	58
62		7,5	6,5	6,5		62
66			6,1	6,1		66
70			5,7			70





 56m	 7,3-23,8m LF	 8,5x8,52m	 122t	 360°	 DIN 75%
------------------------------------------------------------------------------------------	------------------------------------------------------------------------------------------------------	------------------------------------------------------------------------------------------------	-------------------------------------------------------------------------------------------	-------------------------------------------------------------------------------------------	--------------------------------------------------------------------------------------------------

	7,3 0°	17,8 0°	0°	23,8 20°	40°	
14	26,7	20,1				14
16	24,8	18,8	15,8			16
18	23,1	17,7	14,9			18
20	21,5	16,6	14			20
22	20,2	15,6	13,2			22
24	18,9	14,7	12,5	10,2		24
26	17,8	13,9	11,8	9,7		26
28	16,8	13,2	11,1	9,3		28
30	16	12,5	10,6	8,9	7,8	30
34	14,4	11,3	9,5	8,2	7,3	34
38	13,1	10,3	8,7	7,6	6,9	38
42	11,9	9,5	7,9	7	6,5	42
46	10,9	8,8	7,3	6,5	6,1	46
50	9,9	8,2	6,7	6,1	5,8	50
54	8,9	7,7	6,2	5,7	5,5	54
58	7,8	7,2	5,8	5,4	5,3	58
62		6,8	5,4	5,2		62
66		6,3	5,1	5		66
70			4,9	4,8		70
74			4,7			74

 51,9m
 SSL30°

 7,3-23,8m
 LF

8,5x8,52m



142t





360°



DIN

75%

	7,3 0°	17,8 0°	0°	23,8 20°	40°	
9	45,4					9
10	43,4					10
12	39,7	22,9	21,4			12
14	36,5	22,9	20,2			14
16	33,6	22,9	19,2			16
18	31,1	22,9	18,1			18
20	28,8	22,1	17,2	12,1		20
22	26,9	20,8	16,2	11,6		22
24	25,1	19,7	15,3	11,2		24
26	23,5	18,6	14,5	10,7	8,5	26
28	22	17,7	13,7	10,3	8,3	28
30	20,7	16,8	12,9	10	8,1	30
34	18,5	15,3	11,7	9,3	7,8	34
38	16,6	14	10,8	8,8	7,5	38
42	15,2	13	10,1	8,3	7,3	42
46	14	12,2	9,4	7,9	7,1	46
50	13	11,5	8,9	7,6	6,9	50
54	9,2	10,8	8,3	7,3	6,9	54
58		10,4	7,8	7,1	6,8	58
62		9	7,4	6,9		62
66			7,1	6,8		66
70			5,2			70





56m
SSL30°



7,3-23,8m
LF



8,5x8,52m



142t



360°



75%



	7,3 0°	17,8 0°	0°	23,8 20°	40°	
10	38,7					10
12	36,6	22,9	21			12
14	34,5	22,9	19,9			14
16	32,6	22,9	18,8			16
18	30,7	21,9	17,8			18
20	28,9	20,9	16,8			20
22	27,2	20	16	11,6		22
24	25,6	19,2	15,2	11,2		24
26	24,1	18,5	14,5	10,7		26
28	22,7	17,8	13,9	10,4	8,3	28
30	21,5	17,2	13,3	10	8,1	30
34	19,2	16	12,3	9,4	7,8	34
38	17,4	14,9	11,4	8,9	7,5	38
42	15,9	13,8	10,5	8,4	7,3	42
46	14,6	12,9	9,7	8	7,1	46
50	13,1	11,9	9	7,7	6,9	50
54	11	11	8,5	7,4	6,8	54
58	7,6	10,2	8	7,1	6,8	58
62		9,2	7,6	6,9	6,8	62
66		7,6	7,3	6,8		66
70			6,8	6,8		70
74			4,1			74

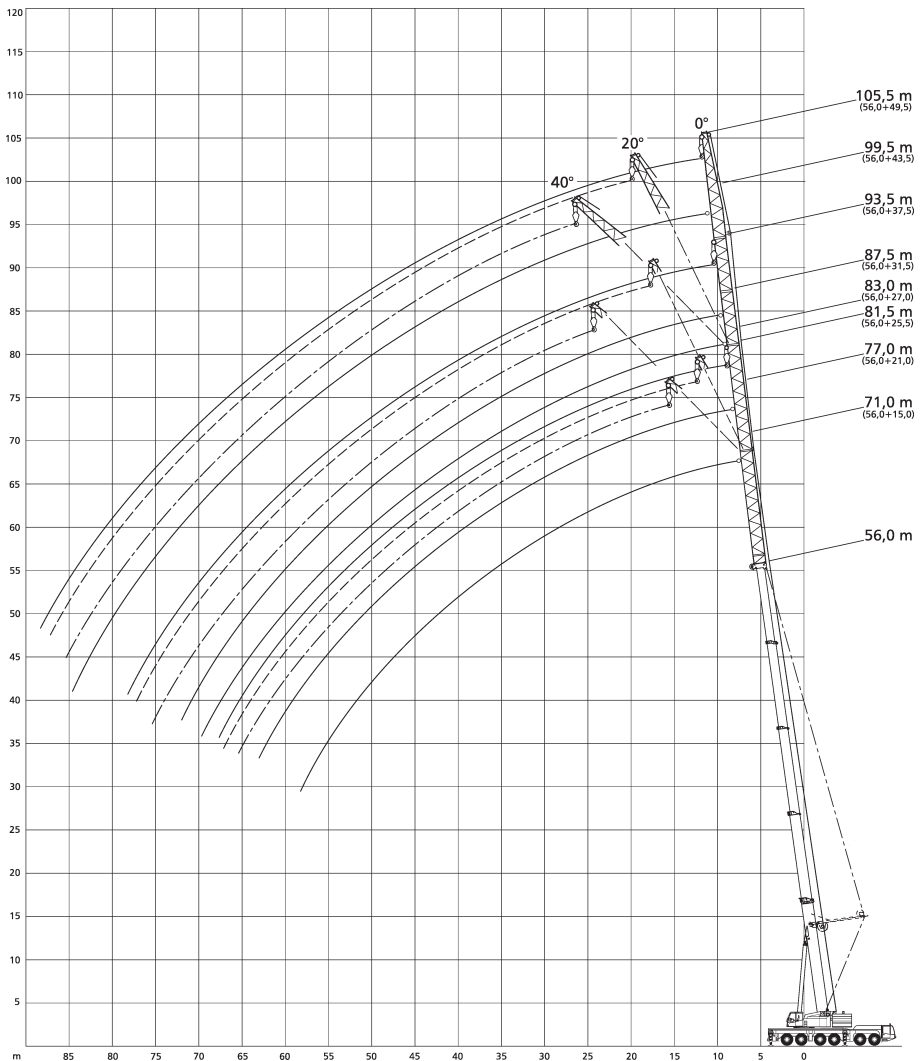

Die Arbeitsbereiche





	15			21			25,5			27			31,5			37,5			43,5			49,5			
	0°	0°	0°	0°	20°	40°	0°	20°	40°	0°	20°	40°	0°	20°	40°	0°	20°	40°	0°	20°	40°				
16	19,1	16,3	14,8																				16		
18	17,8	15,2	13,9	12,4					11,8															18	
20	16,7	14,2	13	11,6					11,2	9,4														20	
22	15,6	13,3	12,3	10,9	10			10,6	9				7,6	5,6										22	
24	14,6	12,5	11,6	10,2	9,4			10	8,6				7,3	5,4										24	
26	13,8	11,7	11	9,6	8,9	8,4	9,5	8,2				7	5,3											26	
28	13	11,1	10,4	9,1	8,4	8	9	7,8	6,8			6,7	5,1											28	
30	12,4	10,4	9,8	8,5	8	7,6	8,6	7,4	6,5			6,5	5											30	
34	11,2	9,4	8,9	7,6	7,2	6,9	7,7	6,7	6	5,7	5,9	4,7	4,6											34	
38	10,3	8,5	8,1	6,9	6,5	6,3	7	6	5,5	5,2	5,3	4,3	4,1	4,1										38	
42	9,5	7,8	7,4	6,2	5,9	5,8	6,3	5,4	5	4,8	4,7	3,8	3,7	3,6										42	
46	8,8	7,1	6,8	5,6	5,4	5,3	5,8	4,9	4,6	4,4	4,2	3,4	3,3	3,2										46	
50	8	6,5	6,3	5,1	5	4,9	5,3	4,4	4,2	4,1	3,8	3	2,9	2,9										50	
54	7,4	6	5,8	4,7	4,6	4,6	4,9	4	3,8	3,7	3,4	2,6	2,6	2,6										54	
58	6,8	5,6	5,4	4,3	4,2	4,2	4,5	3,7	3,5	3,5	3,1	2,3	2,3	2,3										58	
62	6,2	5,2	5	4	3,9		4,2	3,4	3,2	3,2	2,8	2	2	2,1										62	
66	5,4	4,8	4,8	3,7	3,6		3,9	3,1	3	3	2,5	1,8	1,8	1,8										66	
70		4,5	4,5	3,4	3,4		3,7	2,9	2,8	2,8	2,3	1,6	1,6	1,6										70	
74			4,3	3,2	3,2		3,5	2,6	2,6		2,1													74	
78				2,8			3,3	2,4	2,4		1,9													78	
82							3,1	2,3	2,3		1,8													82	
86									2,2										1,6					86	
90																			1,5					90	





51,9m SSL0°	15-49,5m SF	8,5x8,52m	142t	360°	DIN 75%

	15			21		25,5		27			31,5		37,5		43,5		49,5			
	0°	0°	0°	0°	20°	40°	0°	0°	20°	40°	0°	0°	20°	40°	0°	0°	20°	40°		
12	35,3*		26,1*																	12
14	33*	28,9*	24,6*	24,1*				20*												14
16	30,9*	27,2*	23,3*	22,5*				19,1*	16,5*											16
18	29,1*	25,6*	22,1*	21,1*	16,1			18,2*	15,8*					15,1*						18
20	27,3*	24,2*	21*	19,9*	15,4			17,4*	15*					14,3*	12,2*					20
22	25,7*	22,9*	20*	18,8*	14,8	12,9	16,5*	14,2*						13,5*	11,6*					22
24	24,2*	21,7*	19*	17,8*	14,2	12,6	15,8*	13,4*	10,2					12,9*	11*					24
26	22,9	20,5*	18,1*	16,9*	13,6	12,3	15*	12,7*	9,9					12,2*	10,4*					26
28	22,1	19,4*	17,3*	16,1*	13,1	12	14,4*	12,1*	9,6					11,7*	9,9*	7,7				28
30	21,3	18,4*	16,5*	15,3*	12,6	11,7	13,8*	11,6*	9,3	8				11,1*	9,4*	7,5				30
34	19,5	17,1	15,1*	14*	11,8	11,1	12,8*	10,7*	8,7	7,7	10,1*	8,5*	7,1	6,6						34
38	17,8	15,9	13,9*	12,8*	11	10,5	11,9*	9,9*	8,2	7,5	9,3*	7,7*	6,6	6,2						38
42	16,4	14,7	12,8	11,7*	10,4	10	11*	9,2*	7,8	7,1	8,5*	7,1*	6,2	5,8						42
46	15,1	13,7	12,2	10,7*	9,8	9,5	10,2*	8,6*	7,3	6,8	7,8*	6,5*	5,7	5,4						46
50	13,3	12,7	11,6	10	9,3	9,2	9,6*	8*	6,9	6,5	7,1*	6*	5,3	5,1						50
54	11,2	11,7	10,9	9,4	8,9	8,9	9,0*	7,4*	6,6	6,3	6,6*	5,5*	5	4,8						54
58	9,4	9,9	10,4	8,9	8,5	8,6	8,5*	6,9*	6,3	6	6,1*	5,1*	4,6	4,5						58
62		8,4	9,3	7,5	7,9		8,0*	6,5*	6	5,9	5,7	4,7*	4,3	4,3						62
66		6,2	8	6,1	6,4		7,6	6,2*	5,7	5,7	5,4	4,4*	4,1	4,1						66
70			6,1	5	5,2		7,1	5,9*	5,5	5,6	5,1	4,1*	3,9	3,9						70
74							6,0*	5	5,4		4,9	3,9*	3,7	3,7						74
78									4,1	4,5		4,7	3,7*	3,5	3,6					78
82									3,2*	3,5		4,5	3,1	3,3						82
86												3,1	2,4	2,8						86
90													1,7	2						90

*SSL 30°

56m
SSL0°15-49,5m
SF

8,5x8,52m



142t



360°



DIN

75%

	15			21			25,5			27			31,5			37,5			43,5			49,5			
	0°	0°	0°	0°	20°	40°	0°	20°	40°	0°	20°	40°	0°	20°	40°	0°	20°	40°	0°	20°	40°				
12	32,3*																						12		
14	30,2*	26,3*	22,4*																				14		
16	28,4*	24,9*	21,5*	20,6*					18,1*														16		
18	26,7*	23,6*	20,7*	19,6*					17,4*	15,1*													18		
20	25,2*	22,3*	19,8*	18,6*	13,6				16,7*	14,4*							13,5*						20		
22	23,8*	21,2*	19*	17,7*	13,4	12,4			16,1*	13,8*							12,9*	11,4*					22		
24	22,5*	20,1*	18,2*	16,8*	13,1	12,2			15,4*	13,2*							12,3*	10,8*					24		
26	21,2*	19,1*	17,4*	15,9*	12,8	11,9			14,8*	12,6*	9,8						11,8*	10,2*					26		
28	20*	18,1*	16,6*	15,1*	12,5	11,7			14,2*	12,1*	9,5						11,3*	9,7*	6,2				28		
30	19*	17,2*	15,9*	14,4*	12,1	11,4			13,6*	11,6*	9,2						10,8*	9,2*	6,2				30		
34	17,2	15,5*	14,6*	13*	11,3	10,9			12,5*	10,7*	8,7	7,6					9,8*	8,3*	6	5,6			34		
38	16,2	14*	13,4*	11,9*	10,6	10,3			11,5*	9,9*	8,2	7,4					8,9*	7,6*	5,8	5,3			38		
42	15,3	12,8*	12,4*	10,9*	9,9	9,7			10,7*	9,1*	7,7	7,1					8,1*	6,9*	5,6	5			42		
46	14,2	11,9	11,5*	10,1*	9,3	9,2			9,9*	8,4*	7,3	6,8					7,4*	6,3*	5,3	4,8			46		
50	13,1	11,4	10,6*	9,4*	8,8	8,8			9,2*	7,8*	6,9	6,5					6,8*	5,7*	5	4,5			50		
54	11,1	10,8	9,8	8,6*	8,3	8,4			8,5*	7,2*	6,5	6,2					6,3*	5,2*	4,7	4,3			54		
58	9,3	9,8	9,3	8,1	7,9	8			8,0*	6,7*	6,3	6					5,8*	4,8*	4,4	4			58		
62	7,8	8,2	8,9	7,2	7,6				7,5	6,3*	6	5,8					5,4*	4,4*	4,1	3,8			62		
66	4,4*	6,9	7,8	5,9	6,2				7,2	5,9	5,7	5,6					5,1*	4,1*	3,9	3,6			66		
70		4,9	6,6	4,7	5				6,9	5,6	5,4	5,5					4,8*	3,8*	3,6	3,4			70		
74			4,9	3,7	3,8				5,8	4,7	5,2						4,5	3,5	3,4	3,2			74		
78									4,8	3,8	4,3						4,3	3,3	3,2	3			78		
82									2,1*	2,9	3,3						4,2	2,8	3	2,9			82		
86										2,2	2,4						3,5	2,1	2,6				86		
90																	2,2		1,8				90		

*SSL 30°





Die Arbeitsbereiche

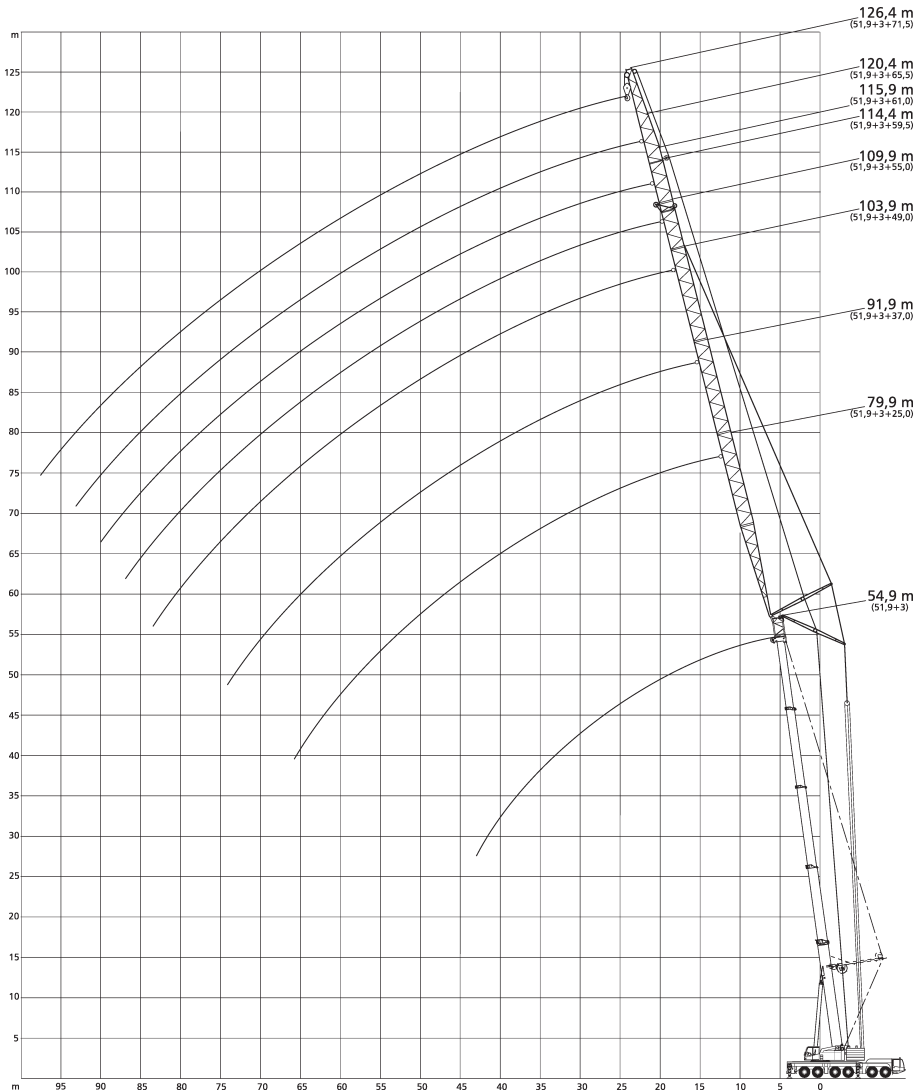

14,2m
82°

25-71,5m



8,5x8,52m



142t



360°



75%

	14,2*								
	25	37	49	55	59,5	61	65,5	71,5	
12	67								12
14	66	44,6							14
16	63	43,8	27,2						16
18	60	43	26,9	21,3					18
20	57	42,2	26,7	21,1	16,7	15,9	13,7		20
22	52	41,3	26,5	20,9	16,7	15,8	13,6	10,2	22
24	42,6	40,5	26,3	20,7	16,6	15,7	13,4	10	24
26		39,6	26	20,5	16,5	15,6	13,3	9,9	26
28		37,5	25,8	20,2	16,4	15,5	13,2	9,7	28
30		34,3	25,6	19,9	16,3	15,5	13,1	9,6	30
32		29,7	25,3	19,5	16,1	15,4	12,9	9,4	32
34		25,3	25,1	19,2	15,9	15,3	12,7	9,3	34
36		20,9	24,6	18,8	15,8	15,2	12,6	9,1	36
38			24,1	18,5	15,6	15,2	12,4	9	38
40			23,3	17,7	15,4	15,1	12,2	8,8	40
42			20,9	16,8	15,2	15	12,1	8,7	42
44			18,4	15,9	14,8	14,8	11,9	8,5	44
46			16	15,1	14,4	14,5	11,7	8,4	46
48			13,4	14,3	14	14,2	11,4	8,2	48
50				13,6	13,6	13,9	11,1	8	50
52				12,9	13	13,2	10,9	7,9	52
54					12,4	12,5	10,6	7,7	54
56					11,8	11,7	10,4	7,6	56
58					10,5	10,2	10,2	7,4	58
60							10	7,3	60
64								7,1	64
68								6,8	68

*+ 3 m Adapter





23,6m
82°



25-71,5m



8,5x8,52m



142t



360°



75%

	23,6*								
	25	37	49	55	59,5	61	65,5	71,5	
14	56								14
16	53	35,3							16
18	50	34,8	21,4						18
20	47,7	34,3	21,2	16,8	14				20
22	45,1	33,8	21,1	16,7	14	13,1	11,2		22
24	42,4	33,3	21	16,6	14	13,1	11,2	8,2	24
26	39,7	32,7	20,9	16,5	14	13,1	11,1	8,1	26
28		32,2	20,7	16,4	14	13,1	11,1	8	28
30		30,4	20,6	16,2	14	13,1	11,1	7,9	30
32		27,9	20,4	16,1	13,9	13,1	11	7,9	32
34		25,5	20,3	15,9	13,8	13,1	10,9	7,8	34
36		23,1	19,9	15,7	13,7	13,1	10,9	7,7	36
38		20,6	19,4	15,6	13,7	13,1	10,8	7,6	38
40			18,5	15,3	13,6	13,1	10,7	7,5	40
42			17,5	15	13,5	13,1	10,6	7,4	42
44			16,6	14,6	13,3	13	10,5	7,3	44
46			15,7	14,2	13,1	12,9	10,5	7,2	46
48			14,7	13,7	12,8	12,7	10,3	7,1	48
50				13,3	12,5	12,5	10,2	7,1	50
52				12,9	12,2	12,2	10,1	7	52
54				12,5	12	12	10	6,9	54
56					11,7	11,7	9,9	6,8	56
58					11,4	11,5	9,8	6,7	58
60					11	11	9,7	6,6	60
64							9,4	6,5	64
68								6,3	68
70								6,2	70

*+ 3 m Adapter

33m
82°

25-71,5m



8,5x8,52m



142t



360°



DIN

75%

	33*								
	25	37	49	55	59,5	61	65,5	71,5	
16	42								16
18	40	25,9							18
20	37,8	25,8	15,7						20
22	35,6	25,7	15,6	12,3	10				22
24	33,9	25,5	15,6	12,3	10	9,1	9		24
26	32,9	25,3	15,5	12,3	10	9,1	9	6,3	26
28	31,8	25	15,5	12,3	10	9,1	9	6,3	28
30		24,8	15,4	12,3	10	9,1	9	6,2	30
32		23,9	15,4	12,3	10	9,1	9	6,2	32
34		23,1	15,3	12,3	10	9,1	9	6,2	34
36		22	15,3	12,3	10	9,1	9	6,1	36
38		20,9	15,2	12,3	10	9,1	9	6,1	38
40			15	12,3	10	9,1	9	6,1	40
42			14,7	12,3	10	9,1	9	6	42
44			14,4	12,3	10	9,1	9	6	44
46			14,1	12,3	10	9,1	9	6	46
48			13,8	12,2	10	9,1	9	5,9	48
50			13,4	12,2	10	9,1	9	5,9	50
52				12,2	10	9,1	9	5,9	52
54				12,2	10	9,1	9	5,8	54
56				12,1	10	9,1	9	5,8	56
58					10	9,1	9	5,8	58
60					10	9,1	9	5,8	60
64							9	5,7	64
68								5,6	68

*+ 3 m Adapter





42,4m
82°



25-71,5m



8,5x8,52m



142t



360°





DIN

75%

	42,4*								
	25	37	49	55	59,5	61	65,5	71,5	
18	26,8								18
20	26,8	16,7							20
22	25,7	16,7	10,5						22
24	24,7	16,7	10,5	8,4					24
26	23,8	16,7	10,5	8,4	7,4	6,5	5,4		26
28	22,9	16,7	10,5	8,4	7,4	6,5	5,4	3,8	28
30	22,1	16,6	10,5	8,4	7,4	6,5	5,4	3,8	30
32		16,6	10,5	8,4	7,4	6,5	5,4	3,8	32
34		16,6	10,5	8,4	7,4	6,5	5,4	3,8	34
36		16,3	10,5	8,4	7,4	6,5	5,4	3,8	36
38		16,2	10,5	8,4	7,4	6,5	5,4	3,8	38
40		15,9	10,5	8,4	7,4	6,5	5,4	3,8	40
42		15,7	10,5	8,4	7,4	6,5	5,4	3,8	42
44			10,5	8,4	7,4	6,5	5,4	3,8	44
46			10,5	8,4	7,4	6,5	5,4	3,8	46
48			10,5	8,4	7,4	6,5	5,4	3,8	48
50			10,5	8,4	7,4	6,5	5,4	3,8	50
52			10,5	8,4	7,4	6,5	5,4	3,8	52
54			10,5	8,4	7,3	6,5	5,4	3,8	54
56				8,4	7,3	6,5	5,4	3,8	56
58				8,4	7,3	6,5	5,4	3,8	58
60					7,3	6,5	5,4	3,8	60
64						6,5	5,4	3,8	64
68							5,4	3,8	68
72								3,8	72

*+ 3 m Adapter



	47,1*								
	25	37	49	55	59,5	61	65,5	71,5	
20	20,2	12,1							20
22	20	12,1							22
24	19,7	12,1	8,2						24
26	19,4	12,1	8,2	6,5	5	4,1			26
28	18,9	12,1	8,2	6,5	5	4,1	3,6		28
30	18,3	12,1	8,2	6,5	5	4,1	3,6	2,3	30
32		12,1	8,2	6,5	5	4,1	3,6	2,3	32
34		12,1	8,2	6,5	5	4,1	3,6	2,3	34
36		12,1	8,2	6,5	5	4,1	3,6	2,3	36
38		12,1	8,2	6,5	5	4,1	3,6	2,3	38
40		12,1	8,2	6,5	5	4,1	3,6	2,3	40
42		12,1	8,2	6,5	5	4,1	3,6	2,3	42
44			8,2	6,5	5	4,1	3,6	2,3	44
46			8,2	6,5	5	4,1	3,6	2,3	46
48			8,2	6,5	5	4,1	3,6	2,3	48
50			8,2	6,5	5	4,1	3,6	2,3	50
52			8,2	6,5	5	4,1	3,6	2,3	52
54			8,2	6,5	5	4,1	3,6	2,3	54
56				6,5	5	4,1	3,6	2,3	56
58				6,5	5	4,1	3,6	2,3	58
60					5	4,1	3,6	2,3	60
64						4,1	3,6	2,3	64
68							3,6	2,3	68
72								2,3	72

*+ 3 m Adapter





51,9m
82°



25-65,5m



8,5x8,52m



142t



360°



75%

	51,9*							
	25	37	49	55	59,5	61	65,5	
22	15	8,5						22
24	15	8,5	5,5					24
26	15	8,5	5,5	4,5				26
28	15	8,5	5,5	4,5	3,3	2,4	2	28
30	14,4	8,5	5,5	4,5	3,3	2,4	2	30
32		8,5	5,5	4,5	3,3	2,4	2	32
34		8,5	5,5	4,5	3,3	2,4	2	34
36		8,5	5,5	4,5	3,3	2,4	2	36
38		8,5	5,5	4,5	3,3	2,4	2	38
40		8,5	5,5	4,5	3,3	2,4	2	40
42		8,5	5,5	4,5	3,3	2,4	2	42
44			5,5	4,5	3,3	2,4	2	44
46			5,5	4,5	3,3	2,4	2	46
48			5,5	4,5	3,3	2,4	2	48
50			5,5	4,5	3,3	2,4	2	50
52			5,5	4,5	3,3	2,4	2	52
54			5,5	4,5	3,3	2,4	2	54
56				4,5	3,3	2,4	2	56
58				4,5	3,3	2,4	2	58
60					3,3	2,4	2	60
64					3,3	2,4	2	64
68							2	68
70							2	70

*+ 3 m Adapter

14,2m
73°

25-71,5m



8,5x8,52m



142t



360°



75%

	14,2*								
	25	37	49	55	59,5	61	65,5	71,5	
18	57								18
20	54								20
22	52	38,6							22
24	48,3	37,6							24
26	44,4	36,6							26
28	39,9	35,6	25						28
30		34,4	24,8	20,5					30
32		32,8	24,4	20,3	16,4	15,5			32
34		31,3	24	20,1	16,4	15,4	13,4		34
36		28,3	23,3	19,6	16,3	15,3	13		36
38		25,3	22,7	19,1	16,2	15,3	12,7	9,7	38
40			21,8	18,3	16	15,2	12,3	9,4	40
42			21	17,6	15,7	15,1	12	9,1	42
44			20	16,8	15,3	15	11,8	8,8	44
46			19	15,9	14,9	14,9	11,5	8,6	46
48			17,9	15,1	14,4	14,6	11,3	8,4	48
50			16,6	14,3	13,9	14,3	11,1	8,2	50
52				13,6	13,4	14	10,9	8	52
54				12,9	12,9	13,6	10,7	7,8	54
56				12,3	12,5	13,2	10,5	7,7	56
58					12	12,7	10,3	7,6	58
60					11,7	12,2	10,2	7,4	60
62						11	10	7,3	62
64							9,8	7,2	64
66							9,6	7,1	66
68								7	68
70								6,8	70
72								6,7	72

*+ 3 m Adapter





23,6m
73°



25-71,5m



8,5x8,52m



142t



360°



DIN

75%

	23,6*								
	25	37	49	55	59,5	61	65,5	71,5	
22	41,7								22
24	39,4								24
26	37,4	34,1							26
28	35,5	32,8							28
30	33,9	31,6	20,4						30
32		30,5	20,2						32
34		29,4	20,1	16,3					34
36		28,5	19,8	16,2	13,9	13,1			36
38		27,6	19,5	16	13,8	13,1	11,1		38
40		26,5	19,1	15,8	13,6	13,1	11	8,1	40
42		24,7	18,7	15,5	13,5	13,1	10,8	7,9	42
44			18,1	15,2	13,3	13,1	10,7	7,7	44
46			17,6	14,9	13,2	13,1	10,5	7,5	46
48			16,9	14,5	13	13	10,4	7,4	48
50			16,3	14,2	12,8	13	10,2	7,2	50
52			15,4	13,7	12,6	12,8	10,1	7,1	52
54			14,6	13,3	12,3	12,6	10	7	54
56				12,7	12,1	12,4	9,9	6,9	56
58				12,2	11,9	12,2	9,8	6,7	58
60					11,6	12	9,8	6,6	60
62					11,3	11,9	9,7	6,6	62
64					11,1	11,7	9,6	6,5	64
66							9,5	6,4	66
68							9,4	6,3	68
70								6,3	70
74								6,2	74

*+ 3 m Adapter

33m
73°

25-71,5m



8,5x8,52m



142t



360°



75%

	33*								
	25	37	49	55	59,5	61	65,5	71,5	
26	27,3								26
28	25,7								28
30	24,5	23,7							30
32	23,6	22,6							32
34	22,8	21,5	15,7						34
36		20,6	15,6						36
38		19,8	15,5	12,3					38
40		19,2	15,4	12,3	10	9,1			40
42		18,6	15,3	12,3	10	9,1	9		42
44		18,3	15,1	12,3	10	9,1	9	6,2	44
46		18	14,9	12,3	10	9,1	9	6,1	46
48			14,6	12,3	10	9,1	9	6,1	48
50			14,3	12,2	10	9,1	9	6	50
52			14	12,1	10	9,1	9	6	52
54			13,7	11,9	10	9,1	9	5,9	54
56			13,3	11,8	10	9,1	9	5,9	56
58				11,6	10	9,1	9	5,8	58
60				11,5	10	9,1	9	5,8	60
64					10	9,1	9	5,7	64
68						9,1	9	5,7	68
72							9	5,6	72
76								5,6	76

*+ 3 m Adapter





42,4m
73°



25-71,5m



8,5x8,52m



142t



360°





DIN

75%

	42,4*								
	25	37	49	55	59,5	61	65,5	71,5	
30	18,3								30
32	17,5								32
34	16,7	16							34
36		15,4							36
38		14,7							38
40		14,2	10,5						40
42		13,6	10,5	8,4					42
44		13,2	10,4	8,4	7,4	6,5			44
46		12,7	10,3	8,4	7,4	6,5	5,4		46
48			10,2	8,3	7,4	6,5	5,4	3,8	48
50			10	8,3	7,4	6,5	5,4	3,8	50
52			9,9	8,3	7,4	6,5	5,4	3,8	52
54			9,7	8,3	7,4	6,5	5,4	3,8	54
56			9,4	8,1	7,4	6,5	5,4	3,8	56
58			9,2	8	7,3	6,5	5,4	3,8	58
60				7,9	7,3	6,4	5,4	3,8	60
64				7,6	7,1	6,3	5,4	3,8	64
68					7	6,1	5,4	3,8	68
72							5,4	3,8	72
76								3,8	76
80								3,8	80

*+ 3 m Adapter



	47,1*								
	25	37	49	55	59,5	61	65,5	71,5	
32	15,1								32
34	14,3								34
36	13,7	12							36
38	13,1	11,7							38
40		11,4							40
42		11,1	8						42
44		10,8	8	6,5					44
46		10,4	7,9	6,5	5	4,1			46
48		10,1	7,8	6,5	5	4,1	3,6		48
50		9,8	7,7	6,5	5	4,1	3,6	2,3	50
52			7,6	6,4	5	4,1	3,6	2,3	52
54			7,5	6,4	5	4,1	3,6	2,3	54
56			7,3	6,3	5	4,1	3,6	2,3	56
58			7,1	6,2	5	4,1	3,6	2,3	58
60			6,9	6,1	5	4,1	3,6	2,3	60
64				5,8	5	4,1	3,6	2,3	64
68					4,9	4,1	3,6	2,3	68
72						4,1	3,6	2,3	72
76							3,6	2,3	76
80								2,3	80

*+ 3 m Adapter







51,9m 73°	25-65,5m	8,5x8,52m	142t	360°	DIN 75%

	51,9*							
	25	37	49	55	59,5	61	65,5	
34	11,3							34
36	10,9							36
38	10,5	8,5						38
40		8,4						40
42		8,3						42
44		8,1	5,5					44
46		7,9	5,5	4,5				46
48		7,7	5,4	4,5	3,3	2,4		48
50		7,5	5,3	4,5	3,3	2,4	2	50
52			5,3	4,5	3,3	2,4	2	52
54			5,2	4,4	3,3	2,4	2	54
56			5,1	4,4	3,3	2,4	2	56
58			5	4,3	3,3	2,4	2	58
60			4,8	4,2	3,3	2,4	2	60
64				4	3,2	2,4	2	64
68				3,7	3,2	2,4	2	68
72					3,1	2,3	2	72
76							2	76

*+ 3 m Adapter



	14,2*								
	25	37	49	55	59,5	61	65,5	71,5	
24	47,2								24
26	43,4								26
28	40,2								28
30	37,5	34,2							30
32		33							32
34		31,8							34
36		30,4	22,9						36
38		28,5	22,7	19					38
40		27,1	22,4	18,4					40
42			22,1	17,8	14,9	15,2			42
44			21,6	17,2	14,7	15	12,2		44
46			21,1	16,5	14,5	14,9	11,9		46
48			20,5	15,8	14,2	14,8	11,7	8,8	48
50			19,8	15,1	14	14,7	11,4	8,6	50
52			18,9	14,4	13,7	14,4	11,2	8,4	52
54				13,7	13,4	14,1	10,9	8,2	54
56				13,1	13	13,7	10,7	8	56
58				12,4	12,7	13,2	10,4	7,8	58
60					12,2	12,7	10,2	7,6	60
64						11,7	9,8	7,2	64
68							9,5	6,9	68
72								6,8	72

*+ 3 m Adapter





23,6m
65°



25-71,5m



8,5x8,52m



142t



360°



75%

	23,6*								
	25	37	49	55	59,5	61	65,5	71,5	
28	33,9								28
30	32,2								30
32	30,7								32
34	29,2	27,2							34
36		26,1							36
38		25,1							38
40		24,2	18,3						40
42		23,3	17,9						42
44		22,4	17,5	15					44
46		21,2	17,1	14,5	12,9				46
48			16,7	14	12,6	12,9			48
50			16,3	13,5	12,4	12,7	10,4		50
52			15,9	13	12,1	12,5	10,2	7,4	52
54			15,4	12,5	11,8	12,4	10	7,3	54
56			15	12,1	11,5	12,1	9,8	7,2	56
58				11,6	11,3	11,9	9,5	7,1	58
60				11,1	11	11,6	9,3	6,9	60
64					10,4	11	9	6,7	64
68						10,5	8,6	6,5	68
72								6,3	72
76								6	76

*+ 3 m Adapter

33m
65°

25-71,5m



8,5x8,52m



142t





360°



DIN

75%

	33*								
	25	37	49	55	59,5	61	65,5	71,5	
34	20,2								34
36	19,4								36
38	18,6								38
40		16,9							40
42		16,1							42
44		15,5							44
46		15	13,3						46
48		14,6	12,8						48
50		14,2	12,2	11,2					50
52			11,8	10,8	9,8	9,1			52
54			11,4	10,5	9,6	9	9		54
56			11,1	10,1	9,4	8,9	8,8		56
58			10,7	9,8	9,1	8,8	8,6	6	58
60			10,5	9,5	8,9	8,7	8,4	6	60
64				9,1	8,5	8,4	8	5,9	64
68					8,1	8	7,7	5,8	68
72						7,4	7,3	5,6	72
76							7	5,4	76
80								5,2	80

*+ 3 m Adapter





42,4m
65°



25-71,5m



8,5x8,52m



142t



360°



DIN

75%

	42,4*								
	25	37	49	55	59,5	61	65,5	71,5	
38	13,4								38
40	12,9								40
42	12,5								42
44		11,2							44
46		10,7							46
48		10,3							48
50		9,9							50
52		9,7	8,3						52
54		9,4	7,9	7,3					54
56			7,6	7					56
58			7,3	6,7	6,3	6			58
60			7,1	6,5	6,1	5,7	5,4		60
64			6,7	6	5,7	5,3	5,2	3,8	64
68				5,7	5,3	4,9	5,1	3,8	68
72					4,9	4,4	4,8	3,8	72
76						4,2	4,7	3,7	76
80							4,5	3,7	80
84								3,6	84

*+ 3 m Adapter

47,1m
65°

25-71,5m



8,5x8,52m



142t





360°



DIN

75%

	47,1*								
	25	37	49	55	59,5	61	65,5	71,5	
42	10,4								42
44									44
46									46
48		8,4							48
50		8,1							50
52		7,8							52
54		7,5	6,4						54
56			6,1						56
58			5,9	5,4					58
60			5,6	5,1	4,9				60
64			5,2	4,7	4,5	3,8	3,6		64
68				4,3	4,1	3,5	3,6	2,3	68
72				3,8	3,6	3,1	3,6	2,3	72
76					3,5	2,9	3,3	2,3	76
80							3,1	2,3	80
84								2,2	84
88								2,2	88

*+ 3 m Adapter







51,9m 65°	25-65,5m	8,5x8,52m	142t	360°	DIN 75%

	51,9*							
	25	37	49	55	59,5	61	65,5	
44	8,2							44
46	7,9							46
48								48
50		6,3						50
52		6						52
54		5,8						54
56		5,5						56
58		5,3	4,1					58
60			3,9	3,3				60
64			3,5	3	2,9	2,3		64
68			3,2	2,7	2,6	2	2	68
72				2,3	2,2	1,6	2	72
76					2		1,9	76
80							1,8	80
84							1,7	84

*+ 3 m Adapter



	33*								
	25	37	49	55	59,5	61	65,5	71,5	
16	42,8								16
18	42,8	26,7							18
20	42,8	26,7	16,1						20
22	42,6	26,7	16,1	12,3					22
24	42,5	26,7	16,1	12,3	10	9,3			24
26	40,7	26,7	16,1	12,3	10	9,3	9	6,3	26
28	37,7	26,7	16,1	12,3	10	9,3	9	6,3	28
30		26,7	16,1	12,3	10	9,3	9	6,3	30
32		26,3	16,1	12,3	10	9,3	9	6,3	32
34		26	16,1	12,3	10	9,3	9	6,3	34
36		25,3	16,1	12,3	10	9,3	9	6,3	36
38		24,6	16,1	12,3	10	9,3	9	6,3	38
40			16,1	12,3	10	9,3	9	6,3	40
42			16,1	12,3	10	9,3	9	6,3	42
44			16,1	12,3	10	9,3	9	6,3	44
46			16,1	12,3	10	9,3	9	6,3	46
48			16,1	12,3	10	9,3	9	6,3	48
50			16,1	12,3	10	9,3	9	6,3	50
52				12,3	10	9,3	9	6,3	52
54				12,3	10	9,3	9	6,3	54
56				12,3	10	9,3	9	6,3	56
58				11	10	9,3	9	6,3	58
60					10	9,3	9	6,3	60
62					10	9,3	9	6,3	62
64							9	6,3	64
66							9	6,3	66
68								6,3	68
70								6,3	70
74								6,3	74

*+ 3 m Adapter





37,7m
82°/SSL0°



25-71,5m



8,5x8,52m



142t



360°



75%

	37,7*								
	25	37	49	55	59,5	61	65,5	71,5	
18	34,5	21,7							18
20	33,7	21,7							20
22	32,9	21,7	13,2						22
24	32,2	21,7	13,2	11,2	9				24
26	31,1	21,4	13,2	11,2	9	8,1	7,2		26
28	29,5	21	13,2	11,2	9	8,1	7,2	5,4	28
30		20,7	13,2	11,2	9	8,1	7,2	5,4	30
32		20,3	13,2	11,2	9	8,1	7,2	5,4	32
34		19,9	13,2	11,2	9	8,1	7,2	5,4	34
36		19,4	13,2	11,2	9	8,1	7,2	5,4	36
38		18,8	13,2	11,2	9	8,1	7,2	5,4	38
40			13,2	11,2	9	8,1	7,2	5,4	40
42			13,2	11,2	9	8,1	7,2	5,4	42
44			13,1	11,2	9	8,1	7,2	5,4	44
46			13,1	11,1	9	8,1	7,2	5,4	46
48			13	11	9	8,1	7,2	5,4	48
50			13	10,9	9	8,1	7,2	5,4	50
52				10,8	9	8,1	7,2	5,4	52
54				10,7	9	8,1	7,2	5,4	54
56				10,6	9	8,1	7,2	5,4	56
58				10,5	9	8,1	7,2	5,4	58
60					9	8,1	7,2	5,4	60
62					9	8,1	7,2	5,4	62
64							7,2	5,4	64
66							7,2	5,4	66
68							7,2	5,4	68
70								5,4	70
74								5,4	74

*+ 3 m Adapter

42,4m
82°/SSL0°

25-71,5m



8,5x8,52m



142t





360°



DIN

75%

	42,4*								
	25	37	49	55	59,5	61	65,5	71,5	
18	26,9								18
20	26,9	16,9							20
22	26,9	16,9	10,7						22
24	26,9	16,9	10,7	8,6					24
26	26,9	16,9	10,7	8,6	7,6	6,5	5,6		26
28	26,4	16,9	10,7	8,6	7,6	6,5	5,6	4	28
30	25,8	16,9	10,7	8,6	7,6	6,5	5,6	4	30
32		16,9	10,7	8,6	7,6	6,5	5,6	4	32
34		16,9	10,7	8,6	7,6	6,5	5,6	4	34
36		16,9	10,7	8,6	7,6	6,5	5,6	4	36
38		16,9	10,7	8,6	7,6	6,5	5,6	4	38
40		16,9	10,7	8,6	7,6	6,5	5,6	4	40
42		16,9	10,7	8,6	7,6	6,5	5,6	4	42
44			10,7	8,6	7,6	6,5	5,6	4	44
46			10,7	8,6	7,6	6,5	5,6	4	46
48			10,7	8,6	7,6	6,5	5,6	4	48
50			10,7	8,6	7,6	6,5	5,6	4	50
52			10,7	8,6	7,6	6,5	5,6	4	52
54			10,7	8,6	7,6	6,5	5,6	4	54
56				8,6	7,6	6,5	5,6	4	56
58				8,6	7,6	6,5	5,6	4	58
60					7,6	6,5	5,6	4	60
62					7,6	6,5	5,6	4	62
64						6,5	5,6	4	64
66						6,5	5,6	4	66
68							5,6	4	68
70							5,6	4	70
74								4	74

*+ 3 m Adapter





47,1m
82°/SSL0°



25-71,5m



8,5x8,52m



142t



360°



75%

	47,1*								
	25	37	49	55	59,5	61	65,5	71,5	
18	20,2								18
20	20,2	12,3							20
22	20,2	12,3							22
24	20,2	12,3	8,4						24
26	20,2	12,3	8,4	6,7	5,2	4,3			26
28	20,2	12,3	8,4	6,7	5,2	4,3	3,9		28
30	20,1	12,3	8,4	6,7	5,2	4,3	3,9	2,6	30
32		12,3	8,4	6,7	5,2	4,3	3,9	2,6	32
34		12,3	8,4	6,7	5,2	4,3	3,9	2,6	34
36		12,3	8,4	6,7	5,2	4,3	3,9	2,6	36
38		12,3	8,4	6,7	5,2	4,3	3,9	2,6	38
40		12,3	8,4	6,7	5,2	4,3	3,9	2,6	40
42		12,3	8,4	6,7	5,2	4,3	3,9	2,6	42
44			8,4	6,7	5,2	4,3	3,9	2,6	44
46			8,4	6,7	5,2	4,3	3,9	2,6	46
48			8,4	6,7	5,2	4,3	3,9	2,6	48
50			8,4	6,7	5,2	4,3	3,9	2,6	50
52			8,4	6,7	5,2	4,3	3,9	2,6	52
54			8,4	6,7	5,2	4,3	3,9	2,6	54
56				6,7	5,2	4,3	3,9	2,6	56
58				6,7	5,2	4,3	3,9	2,6	58
60					5,2	4,3	3,9	2,6	60
62					5,2	4,3	3,9	2,6	62
64						4,3	3,9	2,6	64
66						4,3	3,9	2,6	66
68							3,9	2,6	68
70							3,9	2,6	70
74								2,6	74

*+ 3 m Adapter

51,9m
82°/SSL0°

25-65,5m



8,5x8,52m



142t





360°



DIN

75%

	51,9*							
	25	37	49	55	59,5	61	65,5	
20	15	8,6						20
22	15	8,6						22
24	15	8,6	5,6					24
26	15	8,6	5,6	4,7				26
28	15	8,6	5,6	4,7	3,6	2,9	2,3	28
30	15	8,6	5,6	4,7	3,6	2,9	2,3	30
32		8,6	5,6	4,7	3,6	2,9	2,3	32
34		8,6	5,6	4,7	3,6	2,9	2,3	34
36		8,6	5,6	4,7	3,6	2,9	2,3	36
38		8,6	5,6	4,7	3,6	2,9	2,3	38
40		8,6	5,6	4,7	3,6	2,9	2,3	40
42		8,6	5,6	4,7	3,6	2,9	2,3	42
44			5,6	4,7	3,6	2,9	2,3	44
46			5,6	4,7	3,6	2,9	2,3	46
48			5,6	4,7	3,6	2,9	2,3	48
50			5,6	4,7	3,6	2,9	2,3	50
52			5,6	4,7	3,6	2,9	2,3	52
54			5,6	4,7	3,6	2,9	2,3	54
56				4,7	3,6	2,9	2,3	56
58				4,7	3,6	2,9	2,3	58
60					3,6	2,9	2,3	60
62					3,6	2,9	2,3	62
64					3,6	2,9	2,3	64
66					3,6	2,9	2,3	66
68							2,3	68
70							2,3	70

*+ 3 m Adapter





33m
73°/SSL0°



25-71,5m



8,5x8,52m



142t



360°



DIN

75%

	33*								
	25	37	49	55	59,5	61	65,5	71,5	
28	37,3								28
30	34,7	26,7							30
32	32,6	26,7							32
34	30,4	26,7							34
36		26,7	15,8						36
38		26,4	15,8	12,2					38
40		25	15,8	12,2	10	9,3			40
42		23,6	15,8	12,2	10	9,3	9		42
44		22,5	15,8	12,2	10	9,3	9		44
46		21,4	15,8	12,2	10	9,3	9	6,3	46
48			15,8	12,2	10	9,3	9	6,3	48
50			15,8	12,2	10	9,3	9	6,3	50
52			15,8	12,2	10	9,3	9	6,3	52
54			15,8	12,2	10	9,3	9	6,3	54
56			15,8	12,2	10	9,3	9	6,3	56
58			15	12,2	10	9,3	9	6,3	58
60				12,2	10	9,3	9	6,3	60
62				12,2	10	9,3	9	6,3	62
64					10	9,3	9	6,3	64
66					10	9,3	9	6,3	66
68						9,3	9	6,3	68
70						9,3	9	6,3	70
74							9	6,3	74
78								6,3	78

*+ 3 m Adapter

 37,7m
 73°/SSL0°

25-71,5m



8,5x8,52m





142t



360°



75%

	37,7*								
	25	37	49	55	59,5	61	65,5	71,5	
28	30								28
30	29,2								30
32	28,1	20,1							32
34	27,1	19,7							34
36		19,3							36
38		18,9	12,8						38
40		18,5	12,8	11					40
42		18,1	12,8	10,9	9	8,1			42
44		17,7	12,8	10,8	9	8,1	7,2		44
46		17,3	12,8	10,8	9	8,1	7,2		46
48			12,7	10,7	9	8,1	7,2	5,4	48
50			12,7	10,6	9	8,1	7,2	5,4	50
52			12,6	10,6	9	8,1	7,2	5,4	52
54			12,5	10,5	9	8,1	7,2	5,4	54
56			12,4	10,4	9	8,1	7,2	5,4	56
58			12,3	10,3	9	8,1	7,2	5,4	58
60				10,3	9	8,1	7,2	5,4	60
62				10,2	9	8,1	7,2	5,4	62
64					9	8,1	7,2	5,4	64
66					9	8,1	7,2	5,4	66
68					9	8,1	7,2	5,4	68
70					9	8,1	7,2	5,4	70
74							7,2	5,4	74
78								5,4	78

*+ 3 m Adapter





42,4m
73°/SSL0°



25-71,5m



8,5x8,52m



142t



360°



75%

	42,4*								
	25	37	49	55	59,5	61	65,5	71,5	
30	26								30
32	25,7								32
34	25,3	16,4							34
36		16,4							36
38		16,4	10,4						38
40		16,4	10,4						40
42		16,3	10,4	8,5					42
44		16,2	10,4	8,5	7,6	6,5			44
46		16,1	10,4	8,5	7,6	6,5	5,6		46
48			10,4	8,5	7,6	6,5	5,6	4	48
50			10,4	8,5	7,6	6,5	5,6	4	50
52			10,4	8,5	7,6	6,5	5,6	4	52
54			10,4	8,5	7,6	6,5	5,6	4	54
56			10,4	8,5	7,6	6,5	5,6	4	56
58			10,4	8,5	7,6	6,5	5,6	4	58
60				8,5	7,6	6,5	5,6	4	60
62				8,5	7,6	6,5	5,6	4	62
64				8,5	7,6	6,5	5,6	4	64
66				8,5	7,6	6,5	5,6	4	66
68					7,6	6,5	5,6	4	68
70					7,6	6,5	5,6	4	70
74							5,6	4	74
78								4	78
82								4	82

*+ 3 m Adapter

 47,1m
 73°/SSL0°

25-71,5m



8,5x8,52m



142t



360°

**DIN**

75%

	47,1*								
	25	37	49	55	59,5	61	65,5	71,5	
32	18,7								32
34	18,5	11,9							34
36	18,2	11,9							36
38	17,8	11,9							38
40		11,9	7,8						40
42		11,9	7,8						42
44		11,9	7,8	6,3					44
46		11,8	7,8	6,3	5,2	4,3			46
48		11,8	7,8	6,3	5,2	4,3	3,9		48
50		11,8	7,8	6,3	5,2	4,3	3,9	2,6	50
52			7,8	6,3	5,2	4,3	3,9	2,6	52
54			7,8	6,3	5,2	4,3	3,9	2,6	54
56			7,8	6,3	5,2	4,3	3,9	2,6	56
58			7,8	6,3	5,2	4,3	3,9	2,6	58
60			7,8	6,3	5,2	4,3	3,9	2,6	60
62			7,8	6,3	5,2	4,3	3,9	2,6	62
64				6,3	5,2	4,3	3,9	2,6	64
66				6,3	5,2	4,3	3,9	2,6	66
68					5,2	4,3	3,9	2,6	68
70					5,2	4,3	3,9	2,6	70
74						4,3	3,9	2,6	74
78							3,9	2,6	78
82								2,6	82

*+ 3 m Adapter





51,9m
73°/SSL0°



25-65,5m



8,5x8,52m



142t



360°



75%

	51,9*							
	25	37	49	55	59,5	61	65,5	
32	14							32
34	14							34
36	14	8,3						36
38	14	8,3						38
40		8,3						40
42		8,3	5,1					42
44		8,3	5,1					44
46		8,3	5,1	4,5				46
48		8,3	5,1	4,5	3,6	2,9		48
50		8,3	5,1	4,5	3,6	2,9	2,3	50
52			5,1	4,5	3,6	2,9	2,3	52
54			5,1	4,5	3,6	2,9	2,3	54
56			5,1	4,5	3,6	2,9	2,3	56
58			5,1	4,5	3,6	2,9	2,3	58
60			5,1	4,5	3,6	2,9	2,3	60
62			5,1	4,5	3,6	2,9	2,3	62
64				4,5	3,6	2,9	2,3	64
66				4,5	3,6	2,9	2,3	66
68				4,5	3,6	2,9	2,3	68
70				4,5	3,6	2,9	2,3	70
74					3,6	2,9	2,3	74
78							2,3	78

*+ 3 m Adapter

 33m
 65°/SSL0°

25-71,5m



8,5x8,52m





142t



360°



75%

	33*								
	25	37	49	55	59,5	61	65,5	71,5	
34	28,3								34
36	26,7								36
38	25,1								38
40		23,1							40
42		21,8							42
44		20,7							44
46		19,5	15,5						46
48		18,6	15,5						48
50		17,6	15,5	12,1					50
52			15,5	12,1	10				52
54			15,1	12,1	10	9,3			54
56			14,4	12,1	10	9,3	9		56
58			13,7	12,1	10	9,3	9		58
60			13,1	12,1	10	9,3	9	6,3	60
62			12,6	12,1	10	9,3	9	6,3	62
64				11,7	10	9,3	9	6,3	64
66				11,2	10	9,3	9	6,3	66
68					10	9,3	9	6,3	68
70					10	9,3	9	6,3	70
74						8,9	8,9	6,3	74
78							8,9	6,3	78
82								6,3	82

*+ 3 m Adapter





37,7m
65°/SSL0°



25-71,5m



8,5x8,52m



142t



360°



75%

	37,7*								
	25	37	49	55	59,5	61	65,5	71,5	
36	26								36
38	24,5								38
40									40
42		17,9							42
44		17,6							44
46		17,3							46
48		17							48
50		16,6	12,3						50
52			12,1	10,2					52
54			12	10,1					54
56			11,8	9,9	9	8,1			56
58			11,7	9,8	8,9	8	7,2		58
60			11,7	9,7	8,9	8	7,2		60
62			11,6	9,7	8,8	7,9	7,2	5,4	62
64				9,6	8,8	7,8	7,2	5,4	64
66				9,6	8,7	7,8	7,2	5,4	66
68				9,5	8,7	7,8	7,2	5,4	68
70				9,4	8,6	7,7	7,2	5,4	70
74					8,6	7,7	7,2	5,4	74
78							7,2	5,4	78
82								5,4	82
86								5,4	86

*+ 3 m Adapter

 42,4m
 65°/SSL0°

25-71,5m



8,5x8,52m





142t



360°



75%

	42,4*								
	25	37	49	55	59,5	61	65,5	71,5	
40	22,5								40
42	21,2								42
44		16,2							44
46		16,1							46
48		16							48
50		15,9							50
52		15,5	9,3						52
54		15	9,3						54
56			9,3	8,4					56
58			9,3	8,4	7,6	6,5			58
60			9,3	8,4	7,6	6,5	5,6		60
62			9,3	8,4	7,6	6,5	5,6		62
64			9,3	8,4	7,6	6,5	5,6	4	64
66			9,3	8,4	7,6	6,5	5,6	4	66
68				8,4	7,6	6,5	5,6	4	68
70				8,4	7,6	6,5	5,6	4	70
74					7,6	6,5	5,6	4	74
78						6,5	5,6	4	78
82							5,6	4	82
86								4	86

*+ 3 m Adapter





47,1m
65°/SSL0°



25-71,5m



8,5x8,52m



142t



360°



75%

	47,1*								
	25	37	49	55	59,5	61	65,5	71,5	
42	17,2								42
44									44
46		11,4							46
48		11,3							48
50		11,2							50
52		11,1							52
54		11	7						54
56			7						56
58			7	5,8					58
60			7	5,8	5,2	4,3			60
62			7	5,8	5,2	4,3			62
64			7	5,8	5,2	4,3	3,9		64
66			7	5,8	5,2	4,3	3,9	2,6	66
68				5,8	5,2	4,3	3,9	2,6	68
70				5,8	5,2	4,3	3,9	2,6	70
74				5,8	5,2	4,3	3,9	2,6	74
78					5,2	4,3	3,9	2,6	78
82							3,9	2,6	82
86								2,6	86
90								2,6	90

*+ 3 m Adapter

 51,9m
 65°/SSL0°

25-65,5m



8,5x8,52m



142t



360°



75%

	51,9*							
	25	37	49	55	59,5	61	65,5	
44	12,5							44
46	12,5							46
48		7,9						48
50		7,9						50
52		7,9						52
54		7,9						54
56		7,9	4,6					56
58		7,9	4,6					58
60			4,6	4,1				60
62			4,6	4,1	3,5			62
64			4,6	4,1	3,5	2,8		64
66			4,6	4,1	3,5	2,8	2,3	66
68			4,6	4,1	3,5	2,8	2,3	68
70			4,6	4,1	3,5	2,8	2,3	70
74				4,1	3,5	2,8	2,3	74
78					3,5	2,8	2,3	78
82						2,8	2,3	82
86							2,3	86

*+ 3 m Adapter



